

**Results of
the Laboratory Evaluation of Zenith 5th generation VSB
Television Receiver for Terrestrial Broadcasting**

**Report
(Version 1.1)**

**Prepared by the
By the
Communications Research Centre Canada**

**For
Zenith**

September 2003

Contents

Contents	1
1 Introduction	2
2 Laboratory set-up	3
2.1 Transmitter	3
2.2 Channel	3
2.3 Receiver	3
2.4 Test conditions	3
3 Test Procedures and results	6
3.1 Random Noise impairment	6
3.2 Input Signal RF Dynamic Range	6
3.3 Burst noise impairment	7
3.4 Susceptibility to Single Static Echoes	8
3.5 Susceptibility to Random Noise in the Presence of Static Multipath Ensembles	11
3.6 Susceptibility to Strongest Static Echoes	11
3.7 Susceptibility to Single Dynamic Echoes at Varying Doppler Rates	12
3.8 Susceptibility to Dynamic Echoes in the Presence of Random Noise	12
3.9 Susceptibility to Single Dynamic Echoes at various Delays and Doppler Rates	13
3.10 Receiver Equalizer Range	14
3.10.1 Single Echo	14
3.10.2 Pair Echoes	14
3.11 Single Echo Affecting Pilot	15
3.12 NTSC interference into DTV	15
APPENDIX A	16

1 Introduction

Zenith was interested to evaluate the performance of a VSB television receiver under different laboratory conditions. This receiver was evaluated in the laboratory of the Communications Research Centre Canada against random noise, burst noise and multipath impairments; and co-channel and adjacent channel interference. This document outlines the results of these laboratory evaluations. The tests were carried out in September 2003.

2 Laboratory set-up

The VSB receiver is tested against impairments and interference. The impairments are random noise and burst noise, as well as multipath distortion with and without noise injection. In the case of interference, the tests included adjacent and co-channel interference from NTSC.

The laboratory set-up for the evaluation of the VSB receiver is presented in figure 1. The set-up is divided in three sections: Transmitter, Channel and Receiver.

2.1 Transmitter

The 8-VSB signal is obtained from a Rohde & Schwarz SFQ modulator. The signal source for the 8-VSB modulator is from a video spooler.

2.2 Channel

The RF NTSC signal, used as interference, is obtained from a Drake VM2550A modulator. The NTSC modulator is fed by a video test signal generator and by an audio generator.

A Micronetics NOD-5250 generator is used to generate the random noise. The generator is connected to the combiner along with the desired 8-VSB signal. A controlled gated noise is used with the noise generator to generate the burst noise. An HP89440A vector analyzer is used to calibrate the RF system.

A TAS 4500 FLEX channel simulator is used to simulate multipath distortion.

2.3 Receiver

The output signal from the combiner is connected to the Zenith receiver.

The video signal from the MPEG decoder is connected to a video monitor to determine the TOV level.

2.4 Test conditions

The tests are done on channel 54 (710-716 MHz). In the case of NTSC interference, the tests are done with the desired DTV signal on channel 12 (204-210 MHz).

The video signal from the receiver's output is used to determine the TOV level.

An HP89440A vector analyzer is connected at the combiner output, to make the average power measurement of the DTV, NTSC and random noise signals.

For the C/N measurement in the case of Multipath, the signal power refers to the main signal power (Echo power is not included). Without noise injection, the TAS 4500 FLEX channel simulator has a C/N of 33 dB.

Multipath profile details are listed in Appendix A. Echo phases are referenced to the center of the RF channel.

The tests are conducted with and without signal re-acquisition.

- In this tests procedures “With Signal Re-acquisition (w. re-acq.)” means:

Disconnect the RF signal and re-acquire the signal to find the TOV, where the receiver can re-acquire the signal with the maximum impairment or interference.

- In this tests procedures “Without Signal Re-acquisition (w/o. re-acq.)” means:

Find the TOV with the maximum impairment or interference without re-acquiring the signal.

The NTSC signal used for the power measurement is the RF carrier modulated by a composite video signal with a black level of 7.5 IRE units. The correction factor for the NTSC average power to the visual carrier peak power is +2.60 dB.

For the NTSC undesired signal, the aural carrier is adjusted to 20% (7 dB below) of the visual carrier peak power.

The NTSC video signal is Color Bars. The NTSC audio signal is a 400 Hz tone.

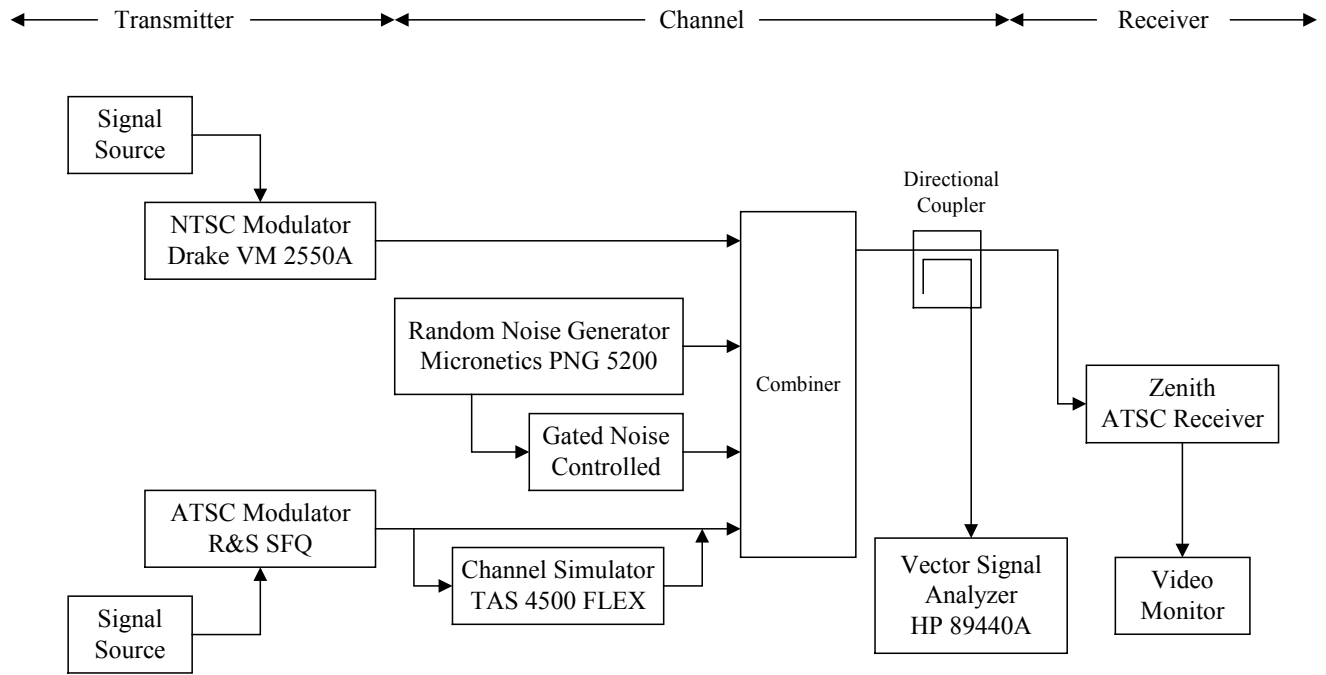

Figure 1: Equipment set-up for laboratory

3 Test Procedures and results

The following procedures are intended to verify the performance of the 8-VSB receiver. These tests include measurements of:

- Random Noise
- Burst Noise
- Input RF Signal Dynamic Range
- Single Echo
- Multipath Ensembles
- NTSC interference

3.1 Random Noise impairment

The purpose of these tests is to determine the robustness of the Zenith receiver to random noise impairment.

The DTV desired signal is adjusted at three different RF levels: Strong (-28 dBm), Moderate (-53 dBm) and Weak (-68 dBm). The noise level is increased until TOV is reached and the C/N value is recorded.

Signal Level	C/N (dB)	
	w/o. re-acq	w. re-acq
Strong	15.6	15.6
Moderate	15.5	15.5
Weak	15.9	15.9

Table 1. Susceptibility to Random Noise

3.2 Input Signal RF Dynamic Range

The ability of the Zenith receiver to receive very strong and very weak signal is tested. The maximum and minimum RF signal level is determined by increasing and decreasing respectively the RF power signal level at the receiver's input until the TOV level is reached.

Minimum RF Level (dBm)		Maximum RF Level (dBm)	
w/o. re-acq	w. re-acq	w/o. re-acq	w. re-acq
-78.4	-78.4	-2.3	-2.3

Table 2. Maximum and minimum RF signal level

3.3 Burst noise impairment

The purpose of this test is to determine the robustness of the Zenith receiver to gated random noise impairment.

The DTV desired signal is adjusted to Moderate level (-53 dBm). The gated noise level is 10 dB above the random noise TOV as measured in section 3.1 (typically -58 dBm : C/N at TOV of 15 dB). The pulse width is increased until TOV is reached and the pulse width is measured and recorded for a pulse rate of 10 and 1 Hz.

Signal Level	C/N (dB)	Pulse Rate (Hz)	Pulse Width (μs)
Moderate	5	10	165
Moderate	5	1	170

Table 3. Susceptibility to Burst Noise with Signal Re-acquisition

3.4 Susceptibility to Single Static Echoes

The purpose of the multipath testing is to determine how robust is the Zenith receiver in the presence of a single static echo with random noise injection over the echo delay range.

The echo power level at TOV is recorded for each scenario of single echo power and delay.

All the multipath tests are done with the desired DTV signal RF level adjusted to the Moderate level (-53 dBm).

Signal Level	Echo Delay (μs)	Doppler Rate (Hz)	C/N (dB)	Echo Power (dB)
Moderate	-60	0.2	33	15.0
Moderate	-57	0.2	33	14.5
Moderate	-54	0.2	33	13.5
Moderate	-51	0.2	33	11.0
Moderate	-48	0.2	33	8.5
Moderate	-42	0.2	33	8.0
Moderate	-36	0.2	33	7.8
Moderate	-30	0.2	33	7.4
Moderate	-24	0.2	33	5.1
Moderate	-18	0.2	33	4.4
Moderate	-12	0.2	33	2.5
Moderate	-6	0.2	33	1.5
Moderate	-3	0.2	33	1.4
Moderate	-1	0.2	33	0.1
Moderate	-0.5	0.2	33	0.1
Moderate	-0.1	0.2	33	0.5
Moderate	0.1	0.2	33	0.6
Moderate	0.5	0.2	33	0.3
Moderate	1	0.2	33	0.2
Moderate	3	0.2	33	1.3
Moderate	6	0.2	33	1.4
Moderate	12	0.2	33	2.6
Moderate	18	0.2	33	4.4
Moderate	24	0.2	33	5.4
Moderate	30	0.2	33	7.6
Moderate	36	0.2	33	8.5
Moderate	42	0.2	33	8.5
Moderate	48	0.2	33	9.0
Moderate	51	0.2	33	11.0
Moderate	54	0.2	33	13.5
Moderate	57	0.2	33	15.0
Moderate	60	0.2	33	15.0

Table 4a. Susceptibility to Single Static Echo without the Presence of Random Noise with Signal Re-acquisition

Signal Level	Echo Delay (μs)	Doppler Rate (Hz)	C/N (dB)	Echo Power (dB)
Moderate	-60	0.2	22	Not tested
Moderate	-57	0.2	22	15.0
Moderate	-54	0.2	22	14.0
Moderate	-51	0.2	22	12.0
Moderate	-48	0.2	22	9.0
Moderate	-42	0.2	22	9.0
Moderate	-36	0.2	22	8.5
Moderate	-30	0.2	22	8.0
Moderate	-24	0.2	22	6.0
Moderate	-18	0.2	22	4.5
Moderate	-12	0.2	22	3.0
Moderate	-6	0.2	22	2.0
Moderate	-3	0.2	22	Not tested
Moderate	-1	0.2	22	0.7
Moderate	-0.5	0.2	22	Not tested
Moderate	-0.1	0.2	22	Not tested
Moderate	0.1	0.2	22	Not tested
Moderate	0.5	0.2	22	Not tested
Moderate	1	0.2	22	1.0
Moderate	3	0.2	22	Not tested
Moderate	6	0.2	22	2.0
Moderate	12	0.2	22	4.0
Moderate	18	0.2	22	4.5
Moderate	24	0.2	22	7.0
Moderate	30	0.2	22	9.0
Moderate	36	0.2	22	9.5
Moderate	42	0.2	22	9.5
Moderate	48	0.2	22	10.0
Moderate	51	0.2	22	12.0
Moderate	54	0.2	22	14.0
Moderate	57	0.2	22	15.0
Moderate	60	0.2	22	15.5

Table 4b. Susceptibility to Single Static Echo in Presence of Random Noise (C/N = 22 dB) with Signal Re-acquisition

Signal Level	Echo Delay (μs)	Doppler Rate (Hz)	C/N (dB)	Echo Power (dB)
Moderate	-60	0.2	18	Not tested
Moderate	-57	0.2	18	16.5
Moderate	-54	0.2	18	15.5
Moderate	-51	0.2	18	13.9
Moderate	-48	0.2	18	11.2
Moderate	-42	0.2	18	10.7
Moderate	-36	0.2	18	10.2
Moderate	-30	0.2	18	9.5
Moderate	-24	0.2	18	7.5
Moderate	-18	0.2	18	6.6
Moderate	-12	0.2	18	4.8
Moderate	-6	0.2	18	3.7
Moderate	-3	0.2	18	Not tested
Moderate	-1	0.2	18	3.4
Moderate	-0.5	0.2	18	Not tested
Moderate	-0.1	0.2	18	Not tested
Moderate	0.1	0.2	18	Not tested
Moderate	0.5	0.2	18	Not tested
Moderate	1	0.2	18	3.2
Moderate	3	0.2	18	Not tested
Moderate	6	0.2	18	3.2
Moderate	12	0.2	18	4.8
Moderate	18	0.2	18	6.5
Moderate	24	0.2	18	7.9
Moderate	30	0.2	18	9.5
Moderate	36	0.2	18	10.4
Moderate	42	0.2	18	10.7
Moderate	48	0.2	18	11.4
Moderate	51	0.2	18	13.8
Moderate	54	0.2	18	15.7
Moderate	57	0.2	18	16.5
Moderate	60	0.2	18	Not tested

Table 4c. Susceptibility to Single Static Echo in Presence of Random Noise (C/N = 18 dB) with Signal Re-acquisition

3.5 Susceptibility to Random Noise in the Presence of Static Multipath Ensembles

The purpose of the multipath testing is to determine how robust is the Zenith receiver in the presence of static multipath ensembles with random noise injection.

The C/N at TOV is recorded for each multipath ensemble.

All the multipath tests are done with the desired DTV signal RF level adjusted to the Moderate level (−53 dBm).

Signal Level	Ensemble Type	C/N (dB)
		w/o. re-acq
Moderate	Calibration	15.6
Moderate	Brazil A	15.6
Moderate	Brazil B	18.6
Moderate	Brazil C	14.4
Moderate	Brazil D	14.5
Moderate	Brazil E	23.8
Moderate	Special Brazil C	16.5

Table 5. Susceptibility to Random Noise in Presence of Static Multipath Ensembles

3.6 Susceptibility to Strongest Static Echoes

The purpose of the multipath testing is to determine how robust is the Zenith receiver in the presence of a strong static echo in static multipath ensembles with and without random noise injection.

The echo power level at TOV is recorded for each multipath ensemble without noise injection.

If the receiver can handle a 0 dB echo without any errors, the C/N is recorded for TOV with noise injection. If not, the maximum echo power is recorded.

All the multipath tests are done with the desired DTV signal RF level adjusted to the Moderate level (−53 dBm).

Signal Level	Ensemble Type	Echo Power (dB)	C/N (dB)
			w/o. re-acq.
Moderate	Calibration	N/A	15.7
Moderate	ACATS #286	0	22.3
Moderate	Modified Brazil C	1.3	N/A
Moderate	Modified Brazil D	0	20.8

Table 6. Susceptibility to Strongest Static Echoes

3.7 Susceptibility to Single Dynamic Echoes at Varying Doppler Rates

The purpose of the multipath testing is to determine how robust is the Zenith receiver in the presence of a single dynamic echo at varying Doppler rates with random noise injection.

The maximum Doppler rate at TOV is recorded for each scenario of single echo power and delay.

All the multipath tests are done with the desired DTV signal RF level adjusted to the Moderate level (-53 dBm).

Signal Level	Echo Delay (μ s)	Echo Power (dB)	C/N (dB)	Doppler Rate (Hz)	
				w/o. re-acq.	w. re-acq.
Moderate	-3	0	25	Not working	Not working
Moderate	-3	-3	25	4	4
Moderate	-3	-10	25	28	28
Moderate	3	0	25	Not working	Not working
Moderate	3	-3	25	4	4
Moderate	3	-10	25	28	28

Table 7. Susceptibility to Single Dynamic Echoes at Varying Doppler Rates

3.8 Susceptibility to Dynamic Echoes in the Presence of Random Noise

The purpose of the multipath testing is to determine how robust is the Zenith receiver in the presence of a dynamic echo in static multipath ensembles with random noise injection.

The echo power level at TOV is recorded for each multipath ensemble.

All the multipath tests are done with the desired DTV signal RF level adjusted to the Moderate level (-53 dBm).

Signal Level	Ensemble Type	Doppler Rate (Hz)	C/N (dB)	Echo Power (dB)	
				w/o. re-acq.	w. re-acq.
Moderate	CRC #1	1	25	2.5	2.5
Moderate	CRC #2	1	25	2.6	2.6
Moderate	CRC #3	1	25	3.3	3.3
Moderate	CRC #4	1	25	3.2	3.2
Moderate	CRC #1	5	25	5.5	5.5
Moderate	CRC #2	5	25	8.1	8.1
Moderate	CRC #3	5	25	9.3	9.3
Moderate	CRC #4	5	25	10.6	10.6

Table 8. Susceptibility to Dynamic Echoes in Presence of Random Noise

3.9 Susceptibility to Single Dynamic Echoes at various Delays and Doppler Rates

The purpose of the multipath testing is to determine how robust is the Zenith receiver in the presence of a single dynamic echo at various delays and Doppler rates with random noise injection.

The echo power at TOV is recorded for each scenario of single echo delay and Doppler rate. All the multipath tests are done with the desired DTV signal RF level adjusted to the Moderate level (-53 dBm).

Signal Level	Echo Delay (μs)	Doppler Rate (Hz)	C/N (dB)	Echo Power (dB)
Moderate	-10	0.2	25	2.0
Moderate	5	0.2	25	1.5
Moderate	15	0.2	25	3.5
Moderate	30	0.2	25	7.5
Moderate	-10	1	25	2.0
Moderate	5	1	25	1.5
Moderate	15	1	25	3.5
Moderate	30	1	25	7.5
Moderate	-10	10	25	5.5
Moderate	5	10	25	5.0
Moderate	15	10	25	6.0
Moderate	30	10	25	8.5
Moderate	-10	20	25	8.5
Moderate	5	20	25	8.0
Moderate	15	20	25	8.5
Moderate	30	20	25	10.0
Moderate	-10	50	25	13.0
Moderate	5	50	25	13.0
Moderate	15	50	25	13.0
Moderate	30	50	25	13.5
Moderate	-10	75	25	15.0
Moderate	5	75	25	15.0
Moderate	15	75	25	15.0
Moderate	30	75	25	15.0

Table 9. Susceptibility to Single Dynamic Echo at various delays in Presence of Random Noise with Signal Re-acquisition

3.10 Receiver Equalizer Range

The purposes of these tests are to characterize the Zenith receiver equalizer range.

3.10.1 Single Echo

The delay of a single echo is changed to determine the range over which the receiver equalizer operates without any noise injection. Doppler frequency of 0.2 Hz is used to ensure inclusion of all phases.

Signal Level	Echo Power (dB)	Doppler Rate (Hz)	C/N	Echo Delay (μ s)	
				Minimum	Maximum
Moderate	-10	0.2	N/A	-48.5	49.5*
Moderate	-6	0.2	N/A	-24.0	25.5
Moderate	-3	0.2	N/A	-13.0	13.0
Moderate	0	0.2	N/A	Not Working	Not Working

Table 10. Receiver Equalizer Range with Signal Re-acquisition

3.10.2 Pair Echoes

The delay of a pair of echoes (pre and post with a 1 μ s offset delay) are increased together to determine the range over which the receiver equalizer operates. No random noise added. Doppler frequency of 0.2 Hz is used to ensure inclusion of all phases.

Signal Level	Echo Power (dB)	Doppler Rate (Hz)	C/N	Echo Delay (μ s)	
				Pre Echo	Post Echo
Moderate	-6	0.2	N/A	-14	15
Moderate	-3	0.2	N/A	-8	9
Moderate	0	0.2	N/A	-3*	4*

*: As there are three equal amplitude signals in this case, the time reference to zero is arbitrarily.

Table 11. Receiver Equalizer Range with Pair Echoes (Pre and Post) with Signal Re-acquisition

3.11 Single Echo Affecting Pilot

The purpose of this test is to determine the robustness of the carrier recovery of the Zenith receiver. The phase of the single echo is adjusted to null out the VSB pilot.

If the receiver can handle a 0 dB echo without any errors, the C/N is recorded for TOV with noise injection. If not, the maximum echo power is recorded.

Signal Level	Ensemble Type			Echo Power (dB)	C/N (dB)
	Delay	Amplitude	Phase		w/o. re-acq.
Moderate	Calibration			N/A	15.6
Moderate	3 μ s	0 dB	180°	0.4	N/A

Table 12. Susceptibility to Random Noise in presence of a Single Echo with Phase Adjusted to Null Out VSB Pilot.

3.12 NTSC interference into DTV

The purpose of this test is to determine the performance of the Zenith receiver under NTSC lower, upper and co-channel interference.

The level of interference (D/U) at TOV is recorded for a typical undesired NTSC test signal (color bars). These tests are done with the DTV signal RF level adjusted to -53 dBm (Moderate) for co-channel interference and -68 dBm (Weak) for lower and upper adjacent channel interference.

Signal Level	Undesired NTSC and Tone Signal	C/N (dB)	D/U (dB)	
			w/o. re-acq.	w. re-acq.
Moderate	Co-channel	N/A	3.1	3.1
Weak	Lower Adjacent	N/A	-42.0	-42.0
Weak	Upper Adjacent	N/A	-41.8	-41.8

Table 13. NTSC and Tone Interference into DTV

APPENDIX A

MULTIPATH PROFILE DETAILS

Multipath Ensemble	Channel Simulator Parameter	Path 1	Path 2	Path 3	Path 4	Path 5	Path 6	
Calibration	Delay (μs)	0	OFF	OFF	OFF	OFF	OFF	
	Attenuation (dB)	0						
	Phase (degrees)	0						
Brazil A	Delay (μs)	0	0.15	2.22	3.05	5.86	5.93	
	Attenuation (dB)	0	13.8	16.2	14.9	13.6	16.4	
	Phase (degrees)	0	0	0	0	0	0	
Brazil B	Delay (μs)	0	0.30	3.50	4.40	9.50	12.70	
	Attenuation (dB)	0	12.0	4.0	7.0	15.0	22.0	
	Phase (degrees)	0	0	0	0	0	0	
Brazil C	Delay (μs)	0	0.089	0.419	1.506	2.322	2.799	
	Attenuation (dB)	2.80	0	3.8	0.1	2.5	1.3	
	Phase (degrees)	0	0	0	0	0	0	
Brazil D	Delay (μs)	0.15	0.63	2.22	3.05	5.86	5.93	
	Attenuation (dB)	0.1	3.8	2.6	1.3	0	2.8	
	Phase (degrees)	0	0	0	0	0	0	
Brazil E	Delay (μs)	0	1.0	2.0	OFF	OFF	OFF	
	Attenuation (dB)	0	0	0				
	Phase (degrees)	0	0	0				
Special Brazil C	Delay (μs)	0	0.089	1.506	1.506	2.322	2.799	
	Attenuation (dB)	2.80	0	20	0	2.5	1.3	
	Phase or Doppler	0°	0°	0.05 Hz	0°	0°	0°	
Modified Brazil C	Delay (μs)	0	0.089	0.419	1.506	2.322	2.799	
	Attenuation (dB)	2.80	0	3.8	Variable	2.5	1.3	
	Phase or Doppler	0°	0°	0°	0.05 Hz	0°	0°	
Modified Brazil D	Delay (μs)	0.15	0.630	2.22	3.05	5.86	5.93	
	Attenuation (dB)	Variable	3.8	2.6	1.3	0	2.8	
	Phase or Doppler	0.05 Hz	0°	0°	0°	0°	0°	
CRC Dynamic	Delay (μs)	0	-1.8	0.15	1.8	5.7	35	
	Attenuation (dB)	#1	0	20	20	10	Varied to reach TOV	18
		#2	0	17	17	7		15
		#3	0	14	14	4		12
		#4	0	11	11	1		9
Phase or Doppler	0	125°	80°	45°	1 or 5 Hz	90°		
ACATS Ensemble A	Delay (μs)	0	-1.8	0.15	1.8	5.7	18	
	Attenuation (dB)	0	20	20	10	Variable	18	
	Phase (degrees)	0	$\phi+288^\circ$	ϕ	$\phi+72^\circ$	$\phi+144^\circ$	$\phi+216^\circ$	

ACATS Ensemble A: Where ϕ is the phase of the shortest echo such that the null within the channel is offset with respect to the carrier (or pilot) frequency by +1.327320 MHz. Once the phase of the shortest delay is found, the phase of the other delay of the ensemble shall be: +72, +144, +216, and +288 degrees with respect to the shortest delay.

Special Brazil C: Echo Path 3 and 4 are assigned same delay (1.506 μs), but different amplitude and phase. The Path 4 is 0 dB amplitude and 0 degree phase, while Path 3 is -20 dB amplitude and 0.05 Hz Doppler phase shift. The combined effect of Path 3 and 4 creates a flat fading environment so that the combined multipath amplitude goes higher and lower than 0 dB in a 0.05 Hz cycle.